

中型全自动打包机

Medium-Sized Full Automatic Balers

机器应用

专门用于废纸、废旧纸板，纸箱厂边角料，塑料膜，秸秆等松散物的压缩打包

Usage

Widely used for compressing waste cardboards, cartons, paper, plastic film, straw etc.



Horizontal Tying Bale size
XTY-600W11075-30

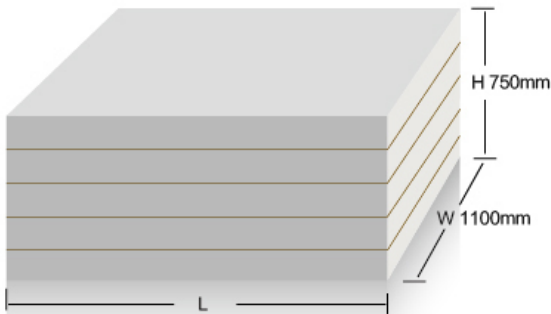

Vertical Tying Bale size
XTY-600W11075-30

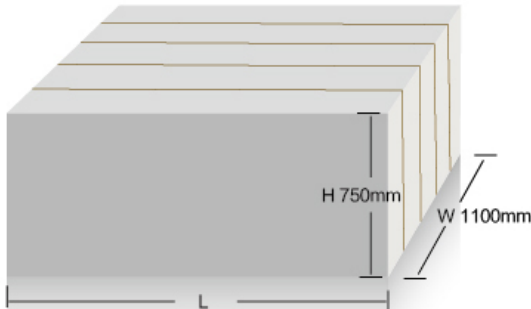

参数 Specifications

型号 Model	XTY-600W11075-30	XTY-800W11080E-30	XTY-800W11075-50 XTY-800W11075KL-50	XTY-800W11075L-50
压力 Pressure	60tons	80tons	80tons	80tons
主电机功率 Main Motor Power	22kw	22kw	37.5kw	37.5kw
冷却方式 Cooling System	air cooler / water cooler	Air cooler/water cooler	air cooler / water cooler	air cooler / water cooler
循环时间 (空载) Cycle Time (unload)	24s	22s	16s	28s
油箱尺寸 Oil Reservoir	1000L	1200L	1100L	1100L
捆包道数 Number of Belting	4lines	4lines	4lines	4lines
捆包铁丝规格 Wire Size	Ø2.7-3.2	Ø2.7-3.2	Ø2.7-3.2	Ø2.7-3.2
加料口尺寸 (L×W) Feed Opening Size (L×W)	1600×1050mm	1300×1050mm	1600×1050mm	2400×1050mm
包块尺寸 Bale Size (L×W×H, L can be adjustable)	L×1100×750mm	L×1100×800mm	L×1100×750mm	L×1100×750mm
打包密度 Bale Density (OCC)	400-500kgs/m ³	420-500kgs/m ³	420-500kgs/m ³	420-500kgs/m ³
产量 (30-60kgs/m ³) Throughput (30-60kgs/m ³)	3-7tons/h	3-6tons/h	4-8tons/h	5-9tons/h
机器重量 Machine Weight	13tons	12tons	14tons	15tons
机器外观尺寸 Machine Overall Dimension	7950×4100×3500mm	6800×4100×3500mm	8100×4100×3500mm 9500×4200×3500mm	9500×4100×3500mm
捆扎方式 Tying	水平捆扎或者垂直捆扎 Horizontal Tying or Vertical Tying			
送料装置 Feeding Device	Conveyor	Conveyor	Conveyor	Conveyor

输送机 Conveyor

宽度 Feeding Width	1600mm	1200mm	1600mm	2000mm
速度 Speed	18m/min	18m/min	18m/min	18m/min
功率 Power	4kw/5.5kw	4kw/5.5kw	4kw/5.5kw	7.5kw
重量 Weight	5tons	4tons	5tons	6tons
外观尺寸 Overall Dimension	9000×2100×4500mm	9400×1550×4300mm	9000×2100×4500mm	9000×2500×4500mm

中型全自动打包机

Middle-Sized Full Automatic Balers

